

CLASSIFIER

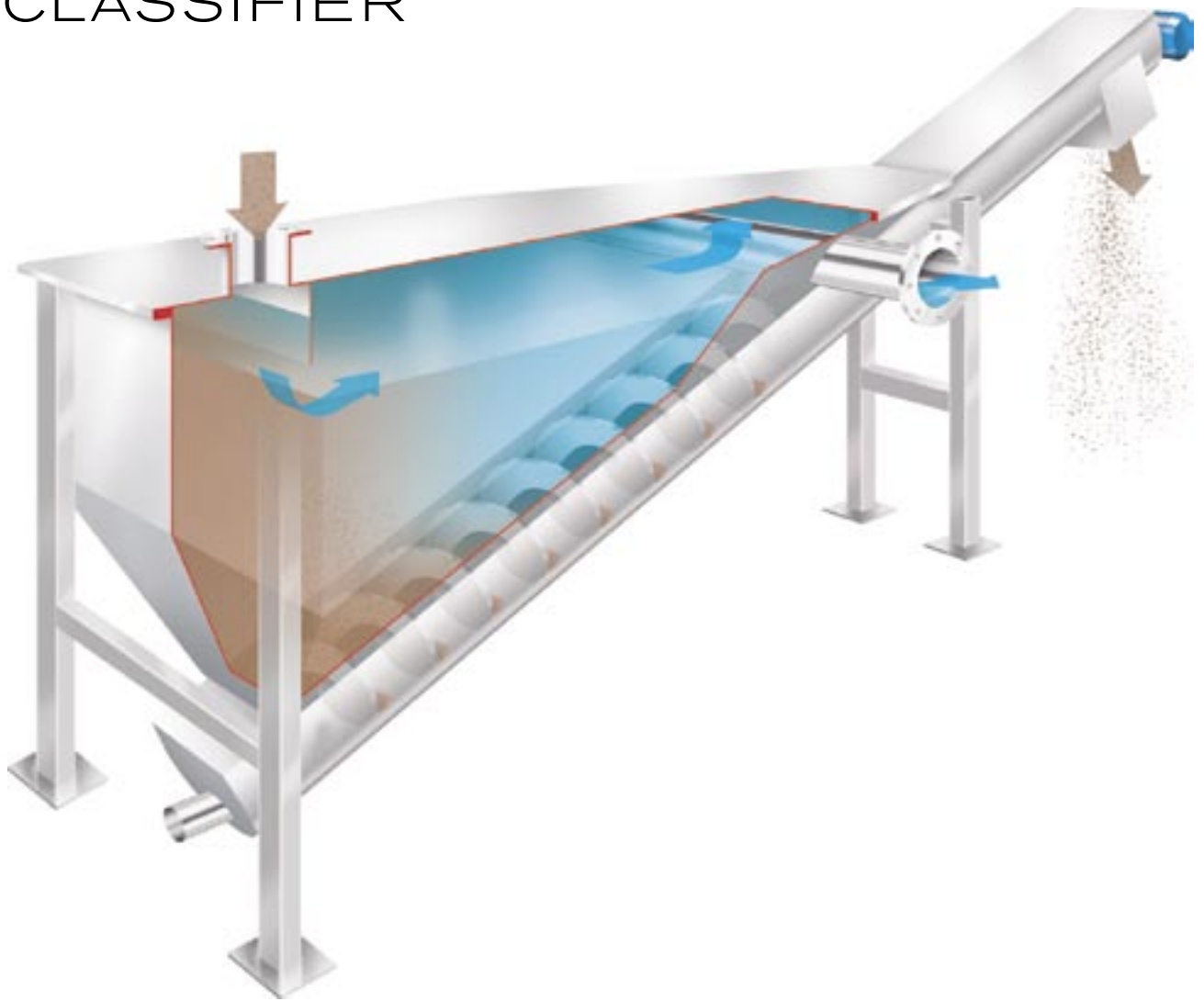

Classifiers from Läckeby Products are designed to separate sand or other types of sedimentary particles. The robust design underpins high reliability and a long technical service life, while maintenance requirements are minimal.

Function

The incoming water flow is led into the wider section of the tank through the top-mounted inlet. A vertical plate creates an even laminar flow, which enables the solid material to settle. The outlet is positioned in the narrow section of the tank, which is fitted with an overflow channel to reduce the risk of particle migration. The tank's walls slope steeply to avoid the risk of bridging. Settled material is transported out via a shaftless pulling spiral for maximum dewatering. This shaftless spiral reduces the need for maintenance, as there is no bearing at the bottom of the through.

Technical features

- Robust design
- Long technical service life
- Shaftless screw conveyor for outfeed of dewatered material
- Without bearing at the bottom end of the conveyor

Process benefits

- Enhances efficiency of separation process for solid material
- Maximises dewatering
- Minimises maintenance

Design

As standard, classifiers are manufactured in stainless steel or acid-proof steel. The unit is fitted with a shaftless spiral made of black material in the bottom of the through. Throughs are coated with Hardox wear bars or Robalon wear liners.



An installation of the SA 260-50 classifier from Läckeby Products.

Technical Data

Model	Flow, l/s	Surface area, m ²	Volume, m ³	Inlet pipe, DN mm	Outlet pipe, DN mm	Motor power, kW	Speed, rpm	Conveyor capacity, m ³ /h
SA 220-20	1-5	1.3	0.5	100	150	0.37	8.2	0.3
SA 260-50	5-12	2.3	1.2	100	150	0.37	8.2	0.35
SA 320-75	12-20	3.0	1.8	150	200	0.37	8.2	0.6
SA 360-100	20-27	4.0	3.3	200	250	0.75	11.0	0.85
SA 420-130	27-35	5.0	4.2	200	250	0.75	11.0	1.45

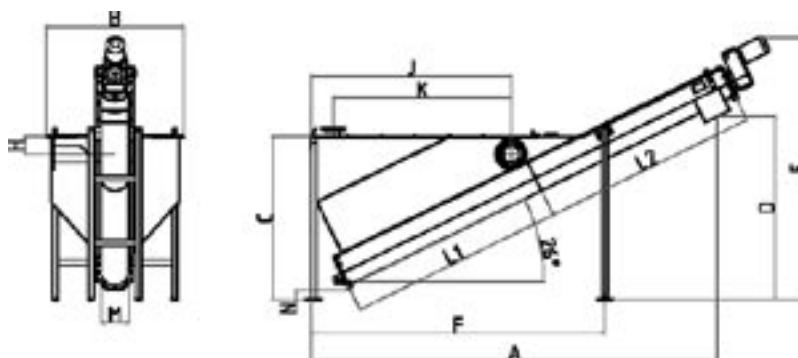

Dimensions

Model	A	B	C	D	E	F	H	J	K	M	N	L1	L2
SA 220-20	2780	820	1100	1200	1700	1714	125	1200	1000	410	100	2000	1000
SA 260-50	3800	1180	1500	1650	2200	2525	150	1800	1600	450	100	3000	1000
SA 320-75	4175	1420	1700	1800	2390	2755	150	2100	1850	510	100	3000	1500
SA 360-100	5585	1420	2150	2460	3100	3725	175	2950	2700	550	100	4000	2000
SA 420-130	6020	1720	2150	2630	3350	3650	175	2850	2600	610	100	4000	2500

References

Läckeby Products has over 100 classifier installations at industrial and municipal plants both in Sweden and abroad.

Läckeby Products develops, designs and manufactures classifiers. Coordinated expertise and production ensures high quality service and delivery. Läckeby Products can also participate in the planning stage and take on responsibility for everything from dimensioning to installation. Through our involvement at the planning stage, we can offer a total process guarantee.

LÄCKEBY PRODUCTS

Läckeby Mosekrogsvägen 2, SE 380 31 Läckeby, Sweden
Phone +46 480-381 00
Fax +46 480-606 63

Kungälv Bultgatan 28, SE 442 40 Kungälv, Sweden
Phone +46 303-24 64 80
Fax +46 303-928 90

www.lackebyproducts.com